

ORIGAMI IRO

Femtosecond Optical Parametric Amplifier



COST-EFFICIENT FS LASER AND OPA

Ideal for pump-probe spectroscopy and material characterization

The ORIGAMI IRO is an advanced Optical Parametric Amplifier (OPA) capable of providing widely tunable, multi- μJ fs pulses ranging from as short as 210 nm up to 11 μm .

Applications

- Optical material & device characterization
- Fs pump probe spectroscopy
- Time-resolved spectroscopy and photoluminescence (TR3, TRPES, TRPL)
- Photoelectron-photoion coincidence spectrometry (PEPICO)
- Coherent anti-Stokes Raman Spectroscopy (CARS)
- Two-dimensional infrared spectroscopy (2D-IR)
- Terahertz emission studies
- Non-linear microscopy

ORIGAMI IRO

Stable and reliable

The OPA is air-cooled and constructed with a sealed and monolithic case design and when coupled with industry-leading pointing stability of the ORIGAMI pump laser, allows for long-term stability and maintenance-free operation.

Fully automated and alignment-free

With appropriate extensions, the ORIGAMI IRO covers a wide wavelength range spanning as wide as 210 nm to 11 μm , while the integrated tuning makes automating experiments simple.

User-friendly by software and hardware design

No need for external beam routing or separation: The integrated tuning and automatic wavelength separation of the ORIGAMI IRO maintain the same beam position and pointing direction for all wavelengths.

Built-in monitoring and PC control

Onboard laser diagnostics and data logging ensure optimal performance and easy troubleshooting. Integrated PC simplifies control in your lab.

210 nm - 2600 nm continuous tunability from a single aperture

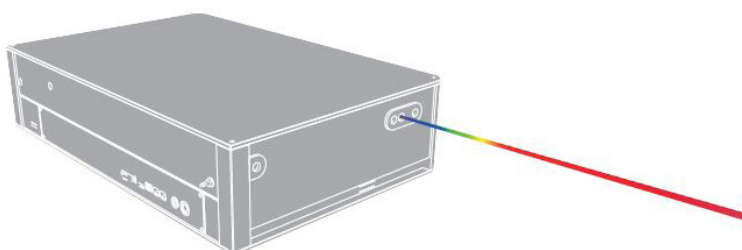

Features

- 8 μJ to 70 μJ pump energy options
- Fully air-cooled laser and OPA
- Available tunability from 210 nm to 11 μm (UV/VIS/MIR)
- Completely automated and fully computer controlled
- Long-life and stable operation with sealed inner case to protect sensitive components
- TCP/IP remote control with standardized command set for easy programming
- 24/7 integrated performance monitoring of both laser system and ORIGAMI IRO
- Optional bypass for SHG green output.
- Full UV/VIS from single aperture
- Industry-leading beam pointing stability maintains alignment in experiments at any wavelength
- Highly stable energy and power for long data collection cycles
- Standard IR bypass with configurable power and simultaneous output capability

Options

- Pulse synchronization capability
- Single laser driving dual OPAs

PERFORMANCE

Typical Power Signal/Idler (40 μ J, 100 kHz pump)

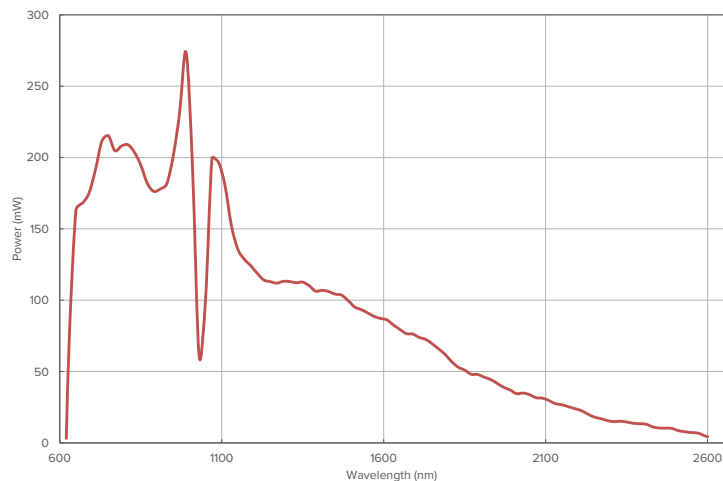

Typical Power UV/VIS Extension (40 μ J, 100 kHz pump)

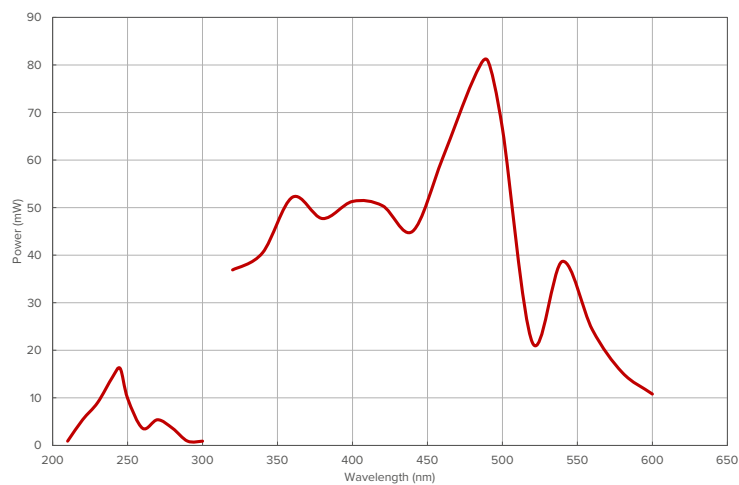

Typical Power IR Extension (40 μ J, 100 kHz pump)

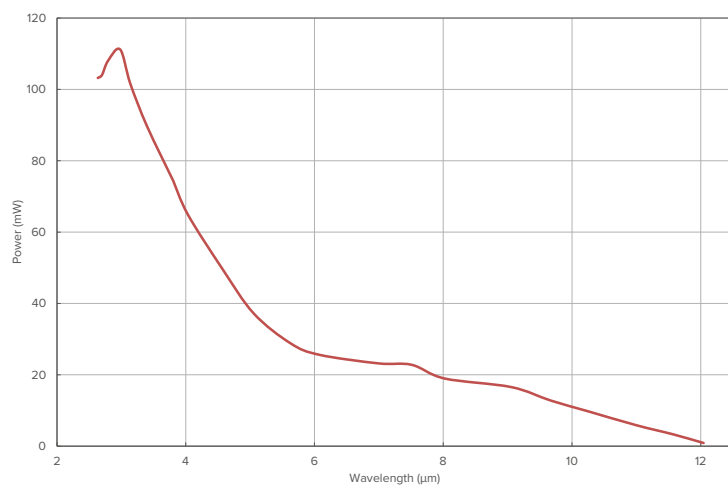

PERFORMANCE

Typical Pulse Duration for <400 fs Input Pump across Signal and Idler

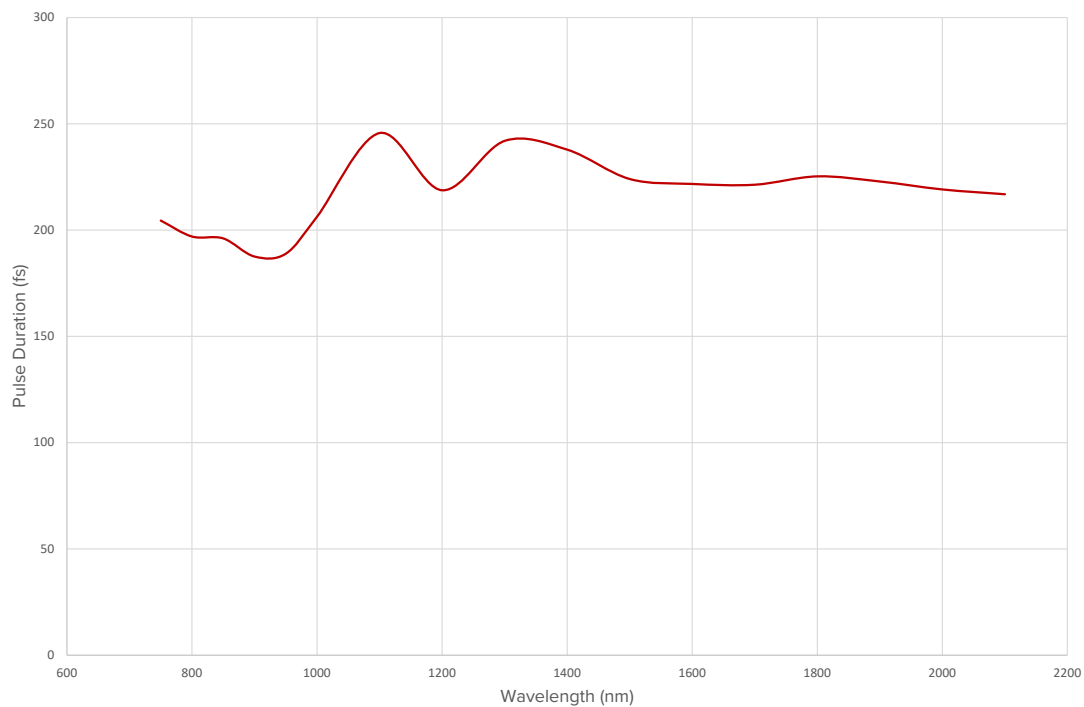

Typical Power Stability Over Time

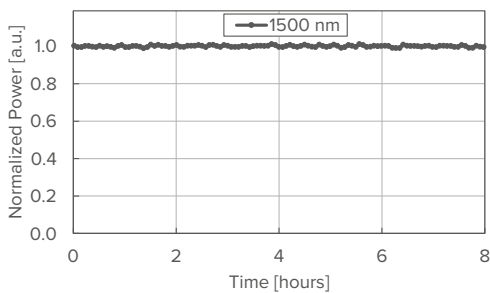
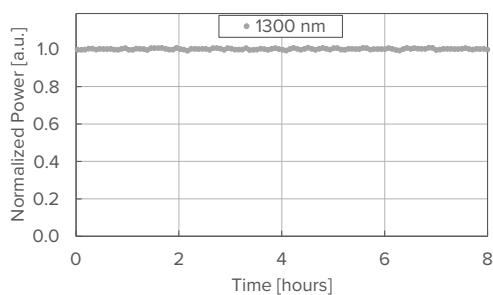
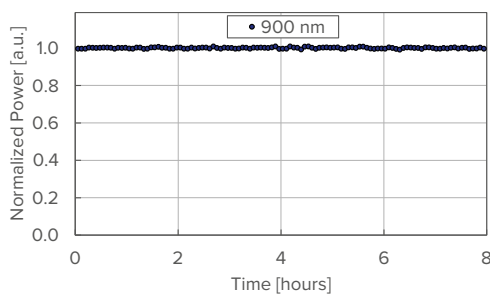
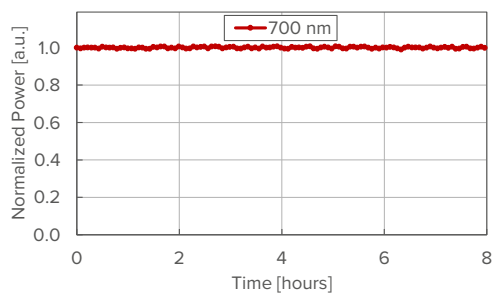

SPECIFICATIONS

Pump Laser Parameters

Input Laser Type	ORIGAMI XP or XPS
Input Power [W]	4 or 5
Input Energy [μ J]	8 - 70
Input Center Wavelength [nm]	1030
Input Polarization	Linear
Repetition Rate [kHz]	Up to 600
Pulse Width	< 400 fs (350 fs typical)

Main Specifications

Conversion Efficiency at Peak	12 %, Signal + Idler
Time Bandwidth Product	< 1
Pulse Width [fs]	< 250
Output Bandwidth, typical [cm^{-1}]	60 - 90 (700-1000 nm), 35 - 80 (1100 - 2500 nm)
Polarization	210 nm - 2600 nm: Horizontal; IR extension: Vertical, Separate
Performance Monitor	Integrated 24/7 monitoring and data logging of both pump laser and OPA conditions (e.g. beam position/pointing, repetition rate, pulse energy)
Wavelength Calibration [nm]	Factory calibrated, ± 2 at 650 - 950 nm
Beam Routing and Separation	Integrated, fully automated (excluding MIR extension, filter change required)
Mechanical Design	Monolithic OPA and UV/VIS option; IR Option separate; Laser separate
Cooling	Air-cooled; OPA & laser
Software, PC, and Automation	Included (Embedded PC)
Remote Control	Possible via TCP/IP (SCPI command set), Windows Remote Desktop

Tuning Range

Base Unit [nm]	Signal: 630 - 1020, Idler: 1040 - 2600
UV/VIS Extension (optional) [nm]	210 - 225, 260 - 510, 520 - 630
IR Extension (optional) [μ m]	Up to 11
	1030 nm Pump Bypass Included
	SHG Bypass, Optional

Environmental Requirements

	Ambient temperature	Relative humidity
During Transportation	5 - 50 °C	< 80%, non-condensing
During Operation	15 - 25 °C	< 60%, non-condensing

TECHNICAL DRAWINGS

Dimensions and Power

Dimensions [mm]	677 mm x 163 mm x 447 mm (See drawings for details; Dimensions may vary depending on options)
Power	100 - 240 V, 50 - 60 Hz, max. 100 W

Pump dimensions

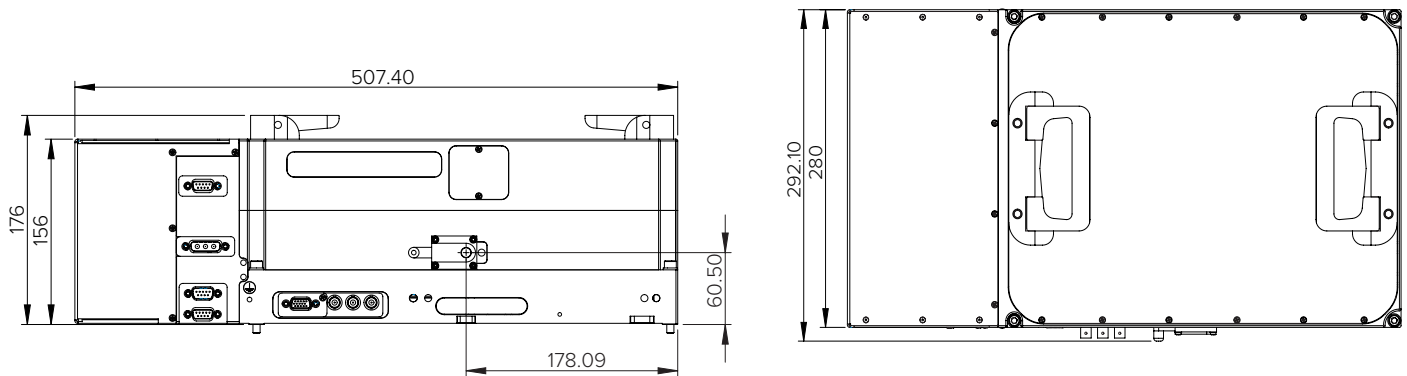

OPA dimensions

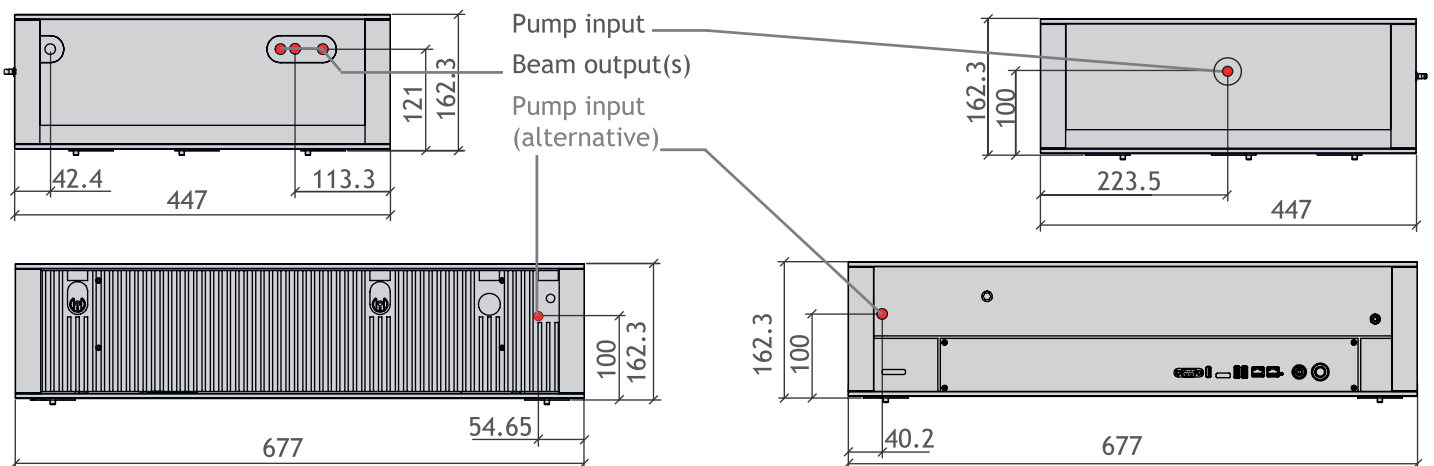

TECHNICAL DRAWINGS

Available Pump and OPA configurations

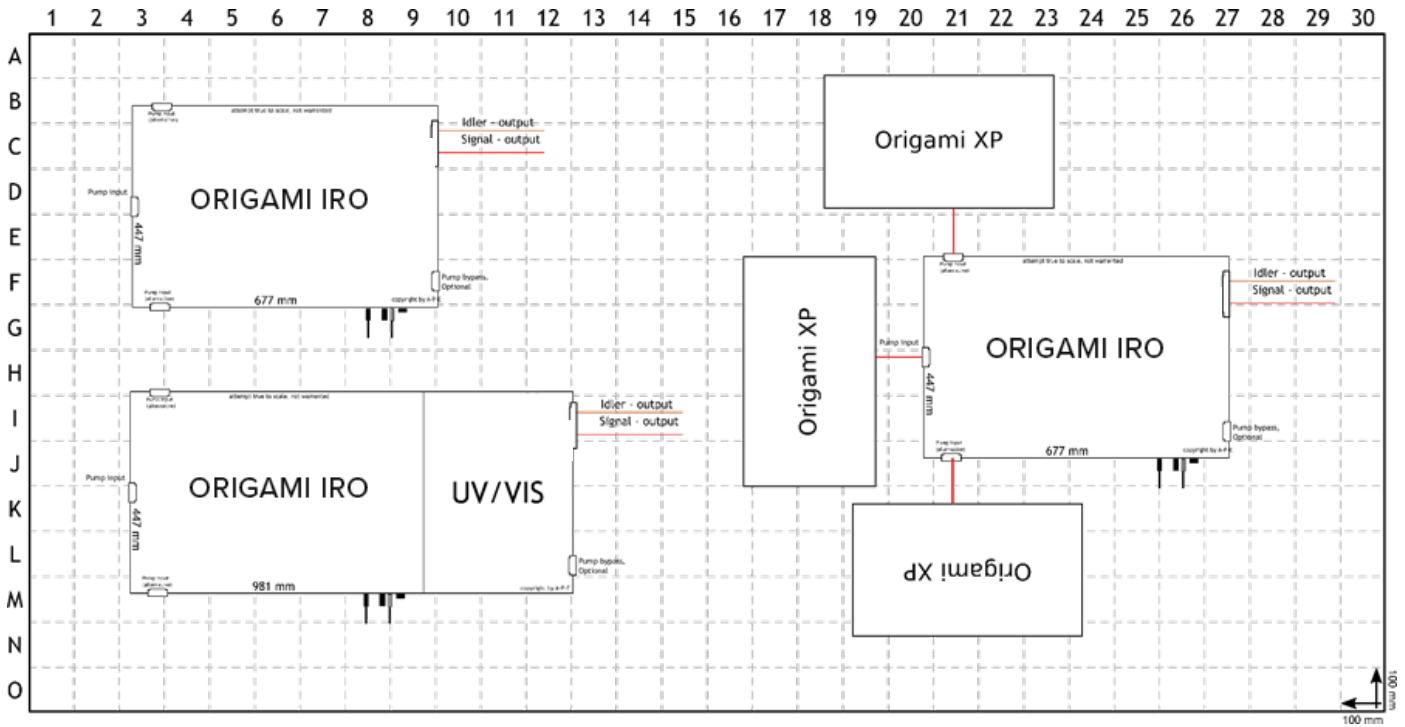

All NKT Photonics products are produced under our quality management system certified in accordance with the ISO 9001:2015 standard.

